

Section : Body
Electrical
Ref. No. : BE-4011
(Revised 2)
Date : Dec., 2004
Page : 1 of 15

Area Application : USA/Canada, Europe, General, G.C.C. Countries, Australia

Model Name : ALL MODELS

Model Code : All Models

Subject : Sensor Inspection for Air Conditioning System

This service bulletin contains inspection procedures to more precisely determine whether or not each temperature sensor, the solar radiation sensor and humidity sensor, which are components of the air conditioning system, operate properly. Follow the procedures in this service bulletin when inspecting the following sensors. These contents will be reflected in future repair manuals.

- Room Temperature Sensor
- Ambient Temperature Sensor
- Air Duct Sensor
- Evaporator Temperature Sensor
- Solar sensor
- Room Humidity Sensor

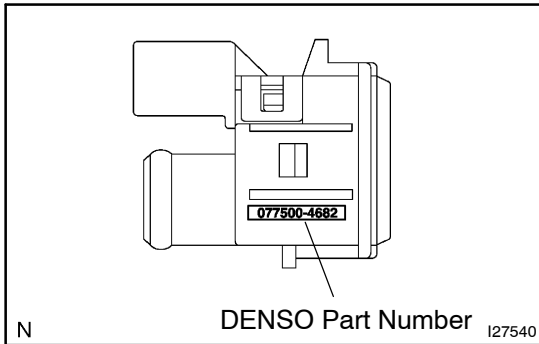

ROOM TEMPERATURE SENSOR

1. INSPECT ROOM TEMPERATURE SENSOR

- (a) Check the DENSO part number indicated on the sensor.
- (b) Select the graph (specification) from the following table according to the number checked in (a).

DENSO Part No.	TOYOTA Part No.	Graph No.	Resistance Value at 25°C (77°F)
077500-1630	88625-90B03	1	5000 ±150 Ω
Except 077500-1630	Except 88625-90B03	2	1700 ±85 Ω

- (c) Measure the sensor resistance according to the selected graph (specification).

NOTICE:

- **Even slightly touching the sensor may change the resistance value. Be sure to hold the connector of the sensor.**
- **When measuring, the sensor temperature must be the same as the ambient temperature.**

HINT:

As the temperature increases, the resistance decreases.

Graph 1:

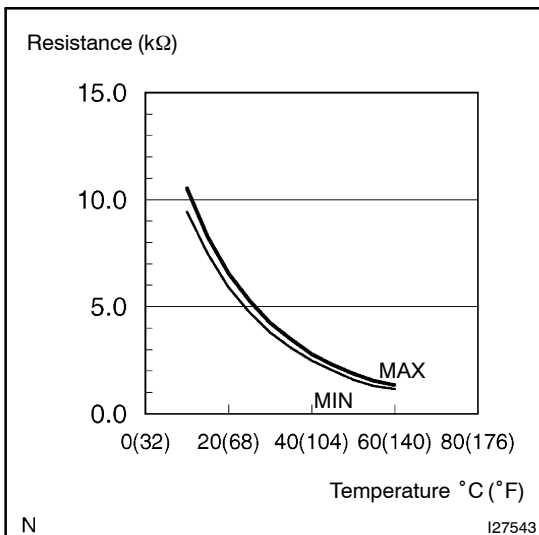

Temperature °C (°F)	Specification kΩ
10 (50)	9.460 to 10.62
15 (59)	7.52 to 8.28
20 (68)	5.95 to 6.60
25 (77)	4.75 to 5.25
30 (86)	3.82 to 4.20
35 (95)	3.09 to 3.40
40 (104)	2.49 to 2.79
45 (113)	2.02 to 2.30
50 (122)	1.65 to 1.90
55 (131)	1.35 to 1.58
60 (140)	1.11 to 1.32

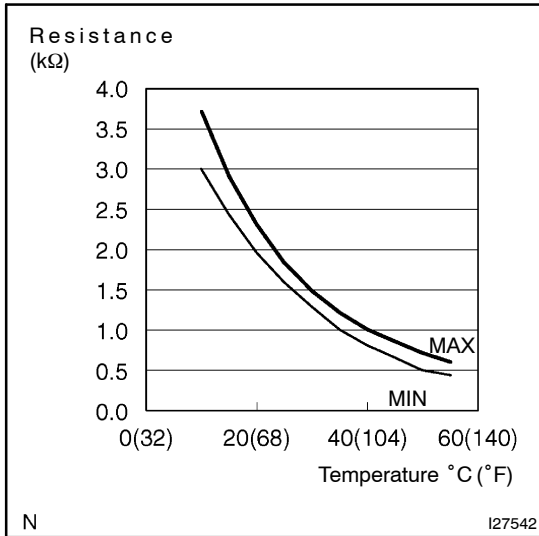

Graph 2:

Temperature °C (°F)	Specification kΩ
10 (50)	3.00 to 3.73
15 (59)	2.45 to 2.88
20 (68)	1.95 to 2.30
25 (77)	1.60 to 1.80
30 (86)	1.28 to 1.47
35 (95)	1.00 to 1.22
40 (104)	0.80 to 1.00
45 (113)	0.65 to 0.85
50 (122)	0.50 to 0.70
55 (131)	0.44 to 0.60
60 (140)	0.36 to 0.50

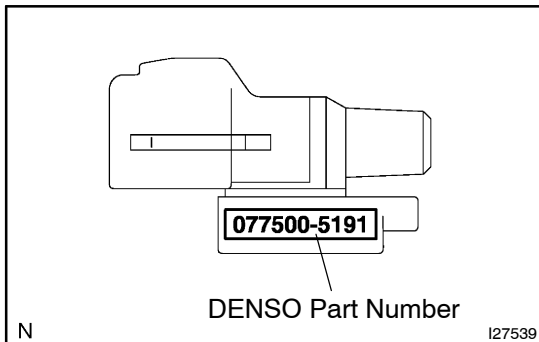

AMBIENT TEMPERATURE SENSOR

- INSPECT AMBIENT TEMPERATURE SENSOR**
 - Check the DENSO part number indicated on the sensor.
 - Select the graph (specification) from the following table according to the number checked in (a).

DENSO Part No.	TOYOTA Part No.	Graph No.	Resistance Value at 25°C (77°F)
077500-1620	88625-90B00	1	461 ±38 Ω
Except 077500-1620	Except 88625-90B00	2	1700 ±85 Ω

(c) Measure the sensor resistance according to the selected graph (specification).

NOTICE:

- Even slightly touching the sensor may change the resistance value. Be sure to hold the connector of the sensor.
- When measuring, the sensor temperature must be the same as the ambient temperature.

HINT:

As the temperature increases, the resistance decreases.

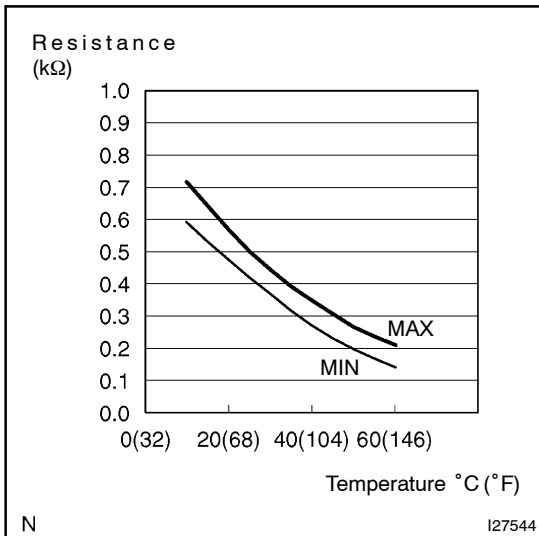

Graph 1:

Temperature °C (°F)	Specification kΩ
10 (50)	0.59 to 0.72
15 (59)	0.53 to 0.64
20 (68)	0.48 to 0.57
25 (77)	0.42 to 0.50
30 (86)	0.37 to 0.44
35 (95)	0.32 to 0.39
40 (104)	0.27 to 0.35
45 (113)	0.23 to 0.31
50 (122)	0.20 to 0.27
55 (131)	0.17 to 0.24
60 (140)	0.14 to 0.21

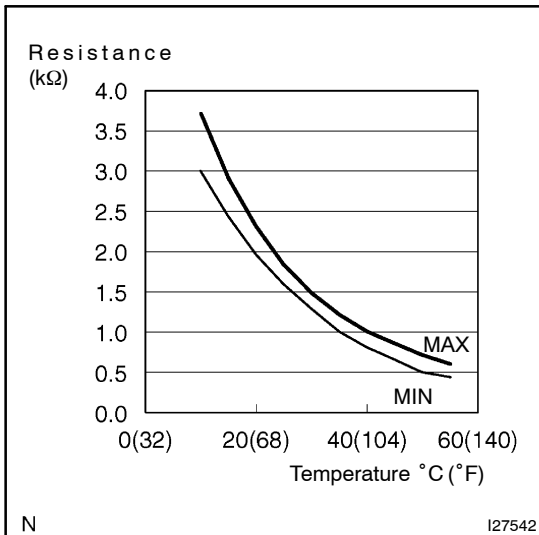

Graph 2:

Temperature °C (°F)	Specification kΩ
10 (50)	3.00 to 3.73
15 (59)	2.45 to 2.88
20 (68)	1.95 to 2.30
25 (77)	1.60 to 1.80
30 (86)	1.28 to 1.47
35 (95)	1.00 to 1.22
40 (104)	0.80 to 1.00
45 (113)	0.65 to 0.85
50 (122)	0.50 to 0.70
55 (131)	0.44 to 0.60
60 (140)	0.36 to 0.50

AIR DUCT SENSOR

1. INSPECT AIR DUCT SENSOR

Measure the sensor resistance according to the table and graph (specification) below.

NOTICE:

- Even slightly touching the sensor may change the resistance value. Be sure to hold the connector of the sensor.
- When measuring, the sensor temperature must be the same as the ambient temperature.

HINT:

As the temperature increases, the resistance decreases.

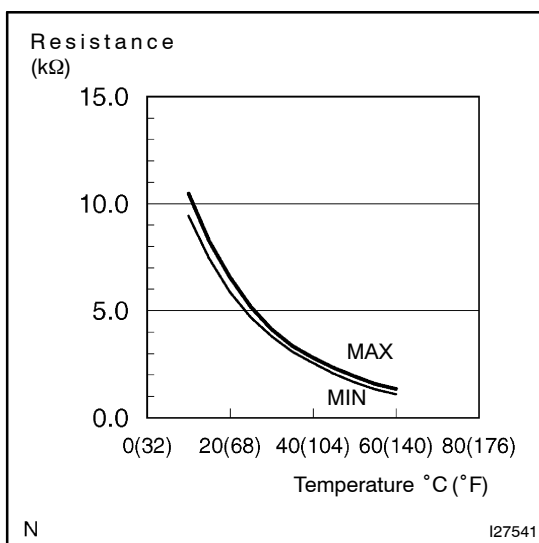

Graph:

Temperature °C (°F)	Specification kΩ
10 (50)	9.48 to 10.49
15 (59)	7.50 to 8.28
20 (68)	5.95 to 6.57
25 (77)	4.77 to 5.25
30 (86)	3.85 to 4.21
35 (95)	3.12 to 3.40
40 (104)	2.53 to 2.79
45 (113)	2.06 to 2.30
50 (122)	1.69 to 1.91
55 (131)	1.39 to 1.59
60 (140)	1.15 to 1.33

EVAPORATOR TEMPERATURE SENSOR

1. INSPECT EVAPORATOR TEMPERATURE SENSOR

(a) Only the 4-digit number is indicated.

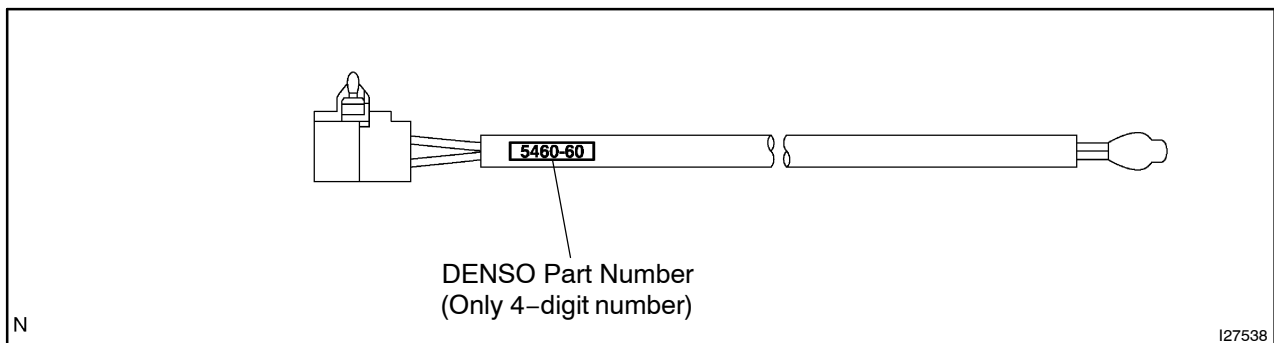

- (b) Select the graph (specification) from the following table according to the number checked in (d).

NOTICE:

Please inspect the sensors for part numbers or graph number not indicated by this Service Bulletin according to the instructions in individual repair manuals.

DENSO Part No.	TOYOTA Part No.	Graph No.	DENSO Part No.	TOYOTA Part No.	Graph No.
077500-0360	88625-20040	2	077500-3672	88625-34010	2
077500-0370	88625-12050	2	077500-3700	88625-50100	2
077500-0380	88625-87001	2	077500-3820	88625-22230	2
077500-0480	88625-60020	2	077500-3841	88625-28130	2
077500-0590	88625-90A00	2	077500-3880	88625-36060	6
077500-0590	88625-95J00	2	077500-4100	88625-36040	2
077500-0710	88625-12070	2	077500-4110	88625-35010	2
077500-0920	88625-95J01	2	077500-4120	88625-35020	2
077500-0940	88625-16060	2	077500-4130	88625-33120	2
077500-0950	88625-87003	2	077500-4130	88625-06020	2
077500-1110	88625-89101	2	077500-4140	88625-33130	2
077500-1211	88625-10020	2	077500-4160	88625-26020	2
077500-1570	88625-12200	2	077500-4160	88625-26030	2
077500-1740	88625-16080	2	077500-4180	88625-36150	2
077500-1761	88625-32040	2	077500-4180	88625-36140	2
077500-2171	88625-89102	2	077500-4200	88625-14120	2
077500-2380	88625-22180	2	077500-4241	88625-26040	2
077500-2431	88625-89103	2	077500-4270	88625-35030	2
077500-2580	88625-20270	2	077500-4280	88625-32150	2
077500-2590	88625-20280	2	077500-4300	88625-50140	2
077500-2740	88625-60060	2	077500-4360	88625-26050	2
077500-3140	88625-12230	2	077500-4420	88625-28150	2
077500-3171	88625-12240	2	077500-4481	88625-42040	2
077500-3270	88625-20350	2	077500-4550	88625-26080	2
077500-3291	88625-02010	2	077500-4650	88625-36061	6
077500-3291	88625-12280	2	077500-4900	88625-60130	2
077500-3340	88625-3A020	2	077500-5071	88625-50160	2
077500-3380	88625-20340	2	077500-5121	88625-02050	2
077500-3420	88625-95A00	2	077500-5200	88625-0D030	2
077500-3450	88625-22170	2	077500-5210	88625-01040	2
077500-3460	88625-60050	2	077500-5241	88625-52050	2
077500-3520	88625-33060	2	077500-5401	88625-33170	3
077500-3530	88625-06010	2	077500-5420	88625-35060	3
077500-3530	88625-33070	2	077500-5420	88625-08010	3
077500-3541	88625-20400	2	077500-5431	88625-35050	3
077500-3551	88625-20390	2	077500-5460	88625-21010	2

Service Bulletin

Ref. No. : BE-4011
(Revised 2)
Page : 7 of 15

077500-5471	88625-35070	3	077500-8260	88625-3A110	2
077500-5480	88625-27010	4	077500-8270	88625-17130	2
077500-5500	88625-02051	3	077500-8300	88625-35040	2
077500-5510	88625-01041	3	077500-8320	88625-0C010	2
077500-5520	88625-48050	1	077500-8350	88625-16210	2
077500-5540	88625-0D030	3	077500-8371	88625-52020	2
077500-5570	88625-02060	2	077500-8380	88625-48030	2
077500-5570	88625-52090	2	077500-8400	88625-20460	2
077500-5580	88625-52100	2	077500-8420	88625-47011	2
077500-5670	88625-60180	4	077500-8450	88625-28170	2
077500-5680	88625-02070	3	077500-8470	88625-60140	2
077500-5700	88625-48060	3	077500-8470	88625-02040	2
077500-5730	88625-12340	3	077500-8480	88625-48040	2
077500-5850	88625-35080	5	077500-8500	88625-60090	2
077500-5860	88625-35090	5	077500-8510	88625-33140	2
077500-5872	88625-02100	1	077500-8520	88625-0C020	2
077500-6111	88625-24050	2	077500-8531	88625-20510	2
077500-7200	88625-48010	2	077500-8550	88625-28180	2
077500-7210	88625-3A120	2	077500-8570	88625-52070	2
077500-7250	88625-26060	2	077500-8671	88625-42080	2
077500-7300	88625-26070	2	077500-9080	88625-11230	2
077500-7310	88625-22250	2	113580-0090	88625-30540	2
077500-7370	88625-0D010	2	113580-0100	88625-22050	2
077500-7400	88625-43010	2	113580-0110	88625-22060	2
077500-7450	88625-42050	2	MF113580-0800	88625-0D070	2
077500-8250	88625-3A090	2			

(c) Measure the sensor resistance according to the selected graph (specification).

NOTICE:

- Even slightly touching the sensor may change the resistance value. Be sure to hold the connector of the sensor.
- When measuring, the sensor temperature must be the same as the ambient temperature.

HINT:

As the temperature increases, the resistance decreases.

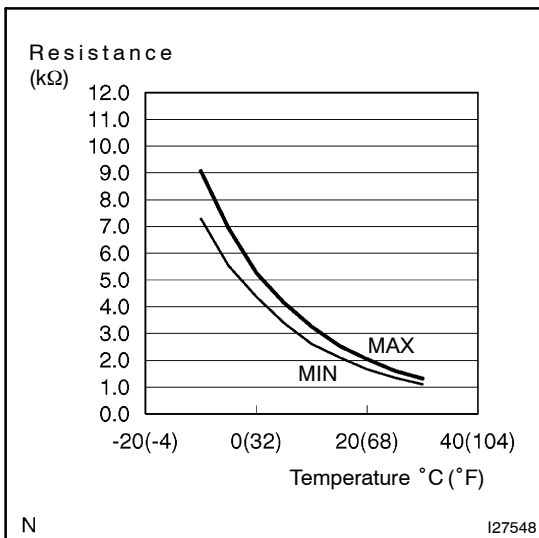

Graph 1:

Temperature °C (°F)	Specification kΩ
-10 (14)	7.30 to 9.10
-5 (23)	5.65 to 6.95
0 (32)	4.40 to 5.35
5 (41)	3.40 to 4.15
10 (50)	2.70 to 3.25
15 (59)	2.14 to 2.58
20 (68)	1.71 to 2.05
25 (77)	1.38 to 1.64
30 (86)	1.11 to 1.32

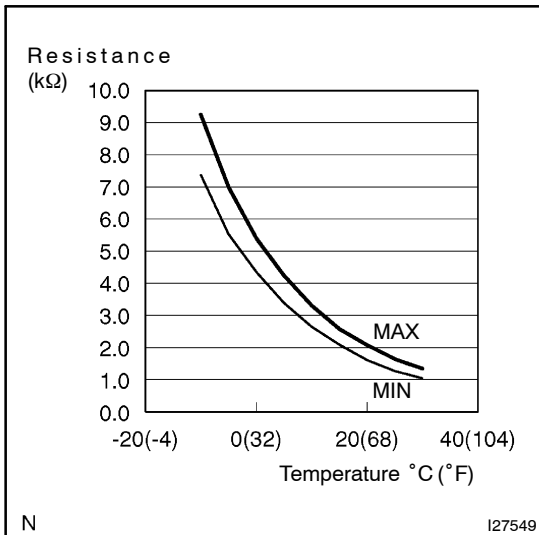

Graph 2:

Temperature °C (°F)	Specification kΩ
-10 (14)	7.40 to 9.20
-5 (23)	5.65 to 7.00
0 (32)	4.35 to 5.40
5 (41)	3.40 to 4.20
10 (50)	2.68 to 3.30
15 (59)	2.10 to 2.60
20 (68)	1.66 to 2.10
25 (77)	1.32 to 1.66
30 (86)	1.05 to 1.35

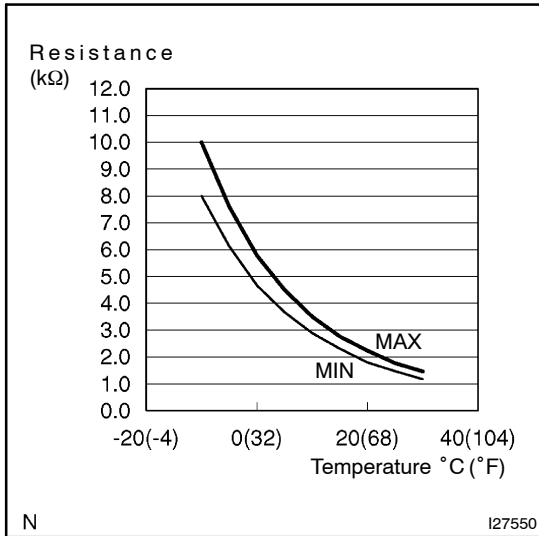

Graph 3:

Temperature °C (°F)	Specification kΩ
-10 (14)	8.00 to 10.00
-5 (23)	6.15 to 7.65
0 (32)	4.75 to 5.85
5 (41)	3.70 to 4.55
10 (50)	2.91 to 3.55
15 (59)	2.32 to 2.80
20 (68)	1.85 to 2.22
25 (77)	1.48 to 1.77
30 (86)	1.20 to 1.43

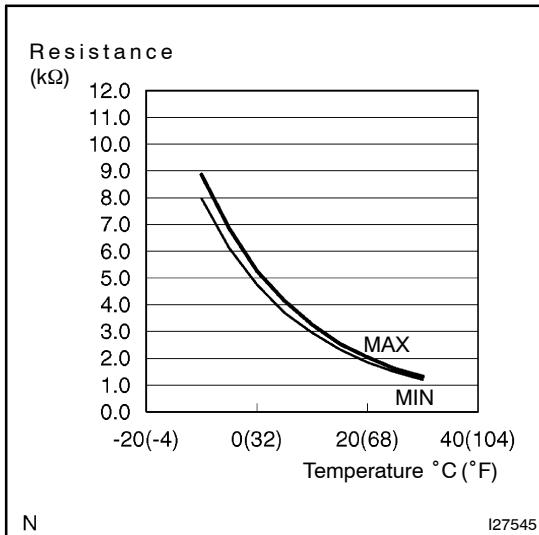

Graph 4:

Temperature °C (°F)	Specification kΩ
-10 (14)	7.98 to 8.90
-5 (23)	6.15 to 6.85
0 (32)	4.78 to 5.30
5 (41)	3.72 to 4.12
10 (50)	2.92 to 3.23
15 (59)	2.31 to 2.55
20 (68)	1.85 to 2.03
25 (77)	1.48 to 1.63
30 (86)	1.19 to 1.32

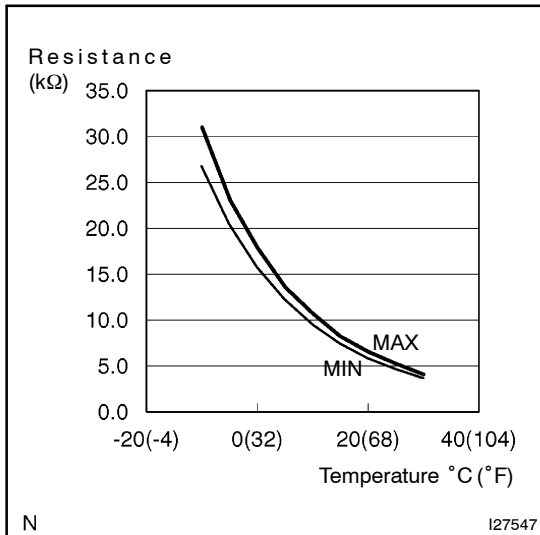
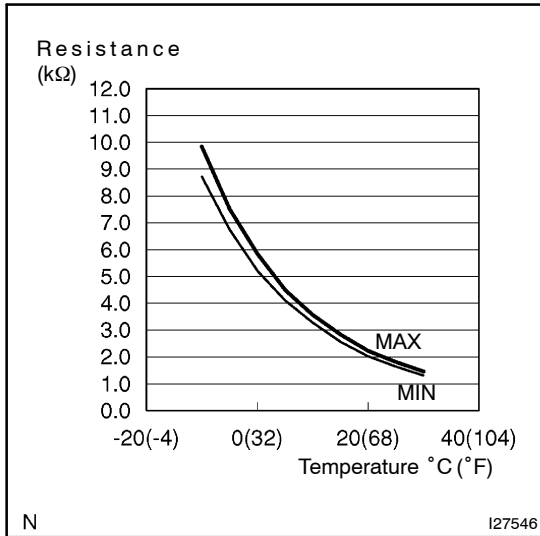

Graph 5:

Temperature °C (°F)	Specification kΩ
-10 (14)	8.80 to 9.85
-5 (23)	6.80 to 7.55
0 (32)	5.28 to 5.86
5 (41)	4.11 to 4.56
10 (50)	3.22 to 3.56
15 (59)	2.56 to 2.82
20 (68)	2.04 to 2.24
25 (77)	1.64 to 1.80
30 (86)	1.32 to 1.46

Graph 6:

Temperature °C (°F)	Specification kΩ
-10 (14)	26.85 to 30.99
-5 (23)	20.62 to 23.28
0 (32)	15.96 to 17.80
5 (41)	12.34 to 13.70
10 (50)	9.60 to 10.65
15 (59)	7.55 to 8.34
20 (68)	6.00 to 6.60
25 (77)	4.75 to 5.25
30 (86)	3.77 to 4.24

SOLAR SENSOR

1. INSPECT SOLAR SENSOR

4 types of solar sensors are used on TOYOTA vehicles depending on the vehicle specifications. The inspection procedure for each type of sensor differs from the others.

Select the appropriate inspection procedure from the table below according to vehicle specifications and perform the inspection.

Automatic Light Control System	Air Conditioning System with Right/Left Independent Temperature Control	Inspection Procedure
Non	Non	A
Non	Equipped	B
Equipped	Equipped	C
Equipped	Non	D

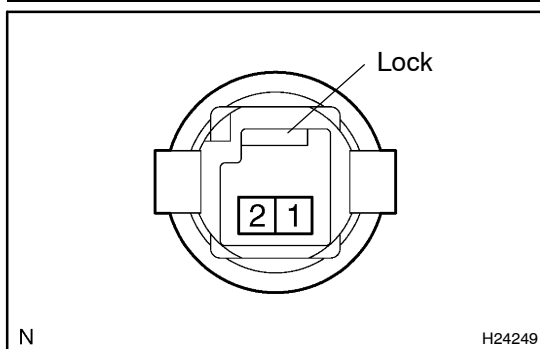

(a) Procedure A:

- (1) Disconnect the solar sensor connector.
- (2) Connect the negative terminal of tester to the terminal 2 of the sensor and connect the positive terminal of the tester to the terminal 1 of the sensor.

NOTICE:

- **The terminal number always starts with 1 from the rightmost side with the connector lock up.**
- **The connection procedure for using a digital tester such as an TOYOTA electrical tester is shown above. When using an analog tester, connect the positive (+) lead to terminal 2 and negative (-) lead to terminal 1 of the solar sensor.**
- (3) Measure the resistance under the following conditions:
 - Covered the sensor with a cloth to avoid direct light.
 - Exposed the sensor to light from a distance of 300 mm (11.81 in.) or less with and inspection light.

HINT:

If the light is weak, the sensor may not react. Be sure to use an incandescent light for an inspection light.

Standard:

Condition	Specification
When the sensor is covered with a cloth (to avoid direct light)	$\infty \Omega$
When the sensor is exposed to light	Except $\infty \Omega$

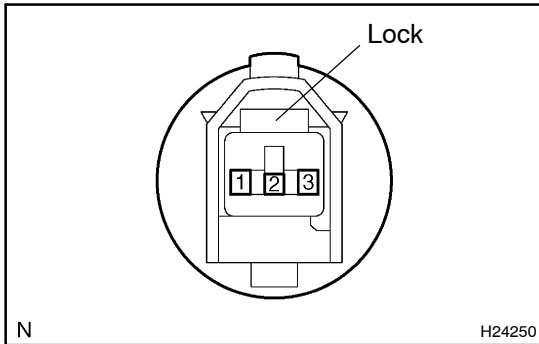

(b) Procedure B:

- (1) Disconnect the solar sensor connector.
- (2) Connect the negative terminal of tester to the terminal 3 of the sensor and connect the positive terminal of the tester to the terminal 2 of the sensor.
- (3) Measure the resistance under the following conditions:
 - Covered the sensor with a cloth to avoid direct light.
 - Exposed the sensor to light from a distance of 300 mm (11.81 in.) or less with and inspection light.

NOTICE:

The connection procedure for using a digital tester such as an TOYOTA electrical tester is shown above. When using an analog tester, connect the positive (+) lead to terminal 3 and negative (-) lead to terminal 2 of the solar sensor.

HINT:

If the light is weak, the sensor may not react. Be sure to use an incandescent light for an inspection light.

Standard:

Condition	Specification
When the sensor is covered with a cloth (to avoid direct light)	$\infty \Omega$
When the sensor is exposed to light	Except $\infty \Omega$

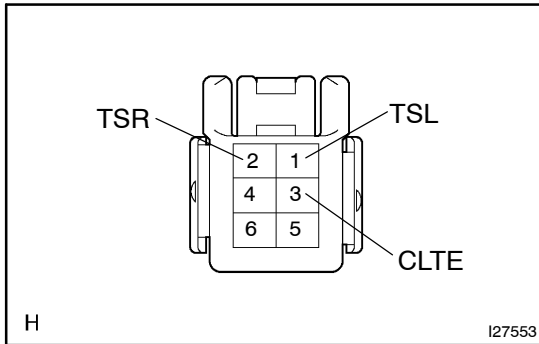

(c) Procedure C:

- (1) Turn the ignition switch ON.
- (2) Using the tester, measure the voltage between terminals TSR (+) and CLTE (-), TSL (+) and CLTE (-) of the connector under the following conditions:
 - Covered the sensor with a cloth to avoid direct light.
 - Exposed the sensor to light from a distance of 300 mm (11.81 in.) or less with and inspection light.

HINT:

- If the light is weak, the sensor may not react. Be sure to use an incandescent light for an inspection light.
- Do not disconnect the solar sensor connector.

Standard:

Condition	Specification
When the sensor is covered with a cloth (to avoid direct light)	Below 0.8 V
When the sensor is exposed to light	4.3 ± 0.3 V

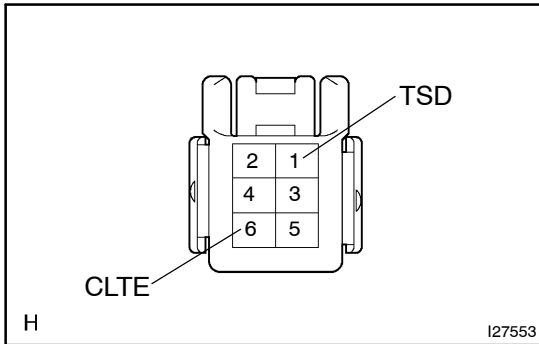

(d) Procedure D:

- (1) Turn the ignition switch ON.
- (2) Using the tester, measure the voltage between terminals TSD (+) and CLTE (-) of the connector under the following conditions:
 - Covered the sensor with a cloth to avoid direct light.
 - Exposed the sensor to light from a distance of 300 mm (11.81 in.) or less with an inspection light.

HINT:

- If the light is weak, the sensor may not react. Be sure to use an incandescent light for an inspection light.
- Do not disconnect the solar sensor connector.

Standard:

Condition	Specification
When the sensor is covered with a cloth (to avoid direct light)	Below 0.8 V
When the sensor is exposed to light	4.3 ± 0.3 V

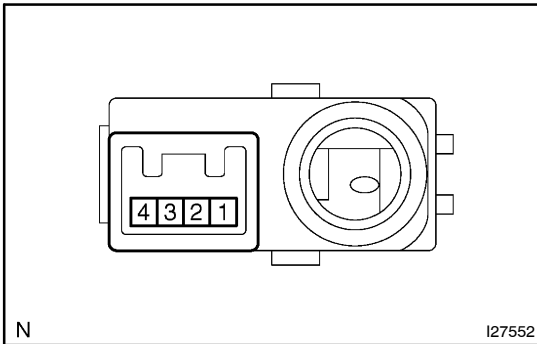

2. ROOM HUMIDITY SENSOR

Measure the humidity and output voltage of the humidity sensor when the sensor is installed on the vehicle and the temperature at the humidity sensor position (room temperature sensor position) is 25°C. If the output voltage is within the specifications according to the graph and table below, the sensor is normal.

HINT:

For the inspection procedure of the room temperature sensor, refer to "ROOM TEMPERATURE SENSOR INSPECTION PROCEDURE".

- (a) Turn the ignition switch ON position.
- (b) Measure the voltage between the terminal VO (3) and GND (2) of the room humidity sensor.

- (c) Measure the humidity and voltage when the room temperature (humidity sensor position) is 25°C. According to the result, determine whether the sensor is normal or not.

Standard:

Humidity (% RH)	Output Voltage at 25°C (77°F)
10	0.70 to 1.08 V
20	0.72 to 1.57 V
30	1.13 to 1.95 V
40	1.61 to 2.24 V
50	1.99 to 2.46 V
60	2.26 to 2.66 V
70	2.48 to 2.85 V
80	2.68 to 3.04 V
90	2.87 to 3.05 V

