

Section : Wind noise/
Squeak/ Rattle
Ref. No. : WS-3001
Date : Aug., 2003
Page : 1 of 13

Area Application : USA/CANADA, Europe, Australia, G.C.C Countries,
General

Model Name : RAV4

Model Code : ACA20, ACA21, ACA26, CLA20, CLA21, ZCA25, ZCA26

Subject : Cowl Area Tick Noise

This is to inform you of a field fix which has been developed to help prevent this noise coming from the front of the passenger compartment when hitting sharp bumps in the road.

Determine root cause of noise (cowl louver or cowl panel). Remove the cowl louver as described below and re-confirm the customer's complaint with a test drive. If the noise is gone, perform the repair instruction pertaining to the cowl louver (page 3 through 7). If the noise is still present, perform the repair procedure for the cowl panel (page 8 through 12).

If a large-sized insulating material has been applied to the part to be repaired and if it maintains the function of insulating, skip the repair of that part. If it has lost the function of insulating, replace it with new one.

Necessary Part Information:

Part Number	Part Name
08231-00801	Interior Noise Kit
08231-00810	Kit, Wind Noise

Service Bulletin

Ref. No. : WS-3001

Page : 2 of 13

Components:

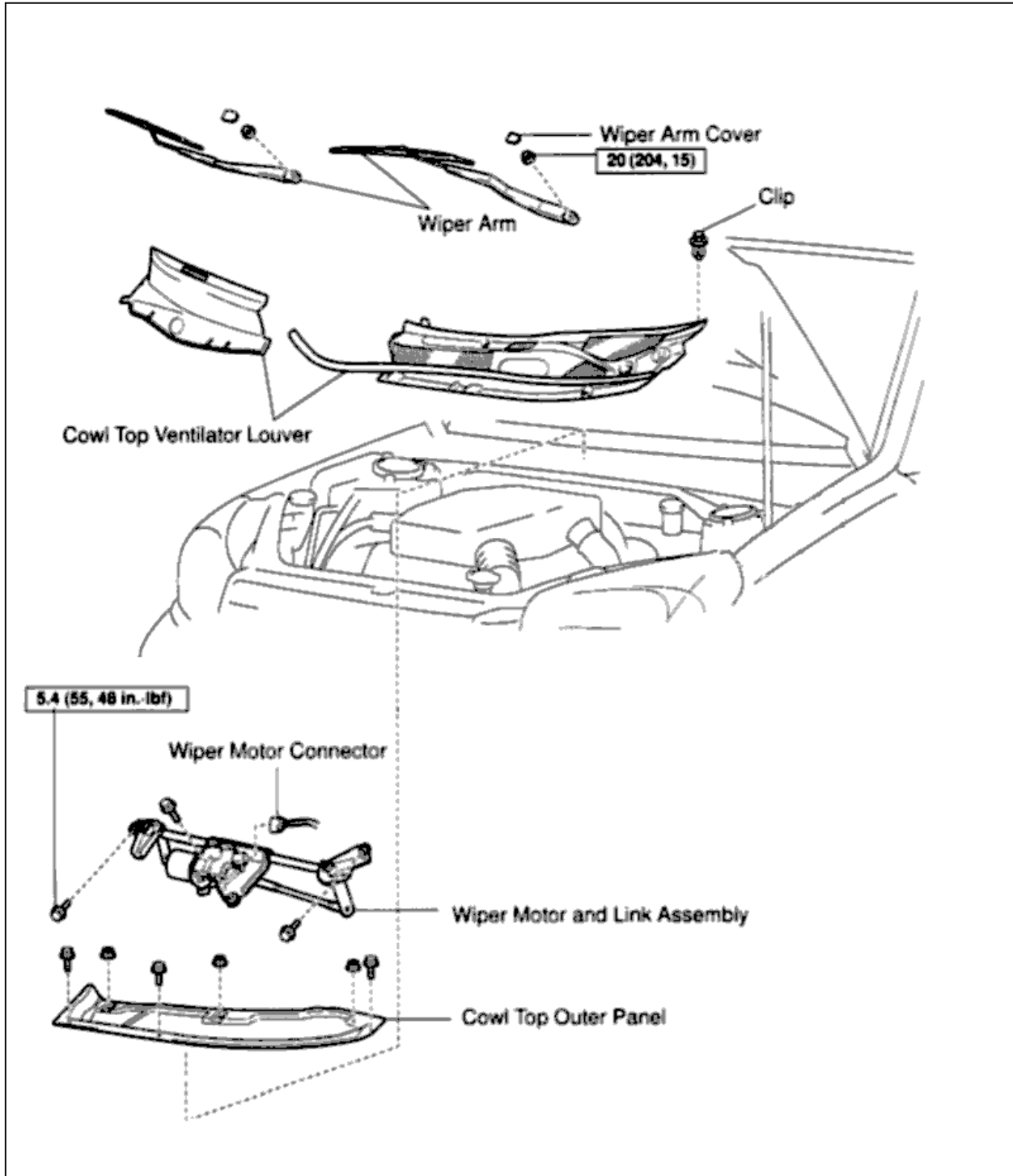

Cowl Louver Field Fix Method

1. Remove both windshield wiper arms.
2. Remove passenger's side cowl top ventilator louver/battery cover.
3. Remove driver's side (center) cowl top ventilator louver.
4. Remove the four original pieces of felt from the driver's side (center) cowl top ventilator louver retainers.

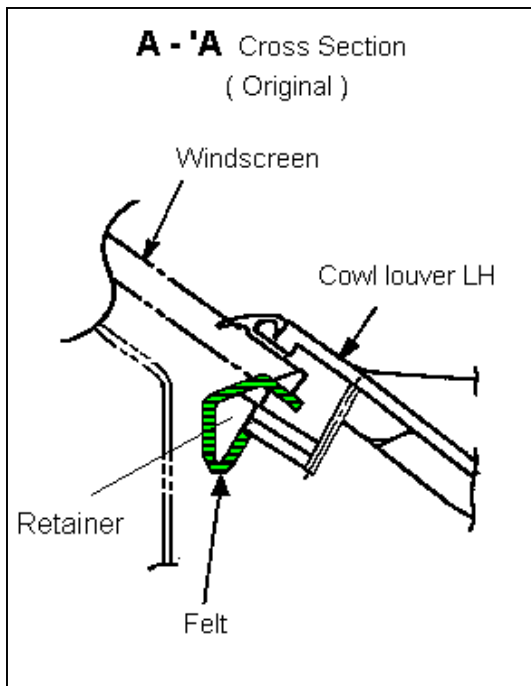
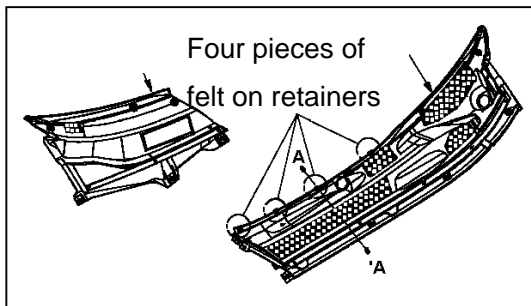

Service Bulletin

Ref. No. : WS-3001
Page : 4 of 13

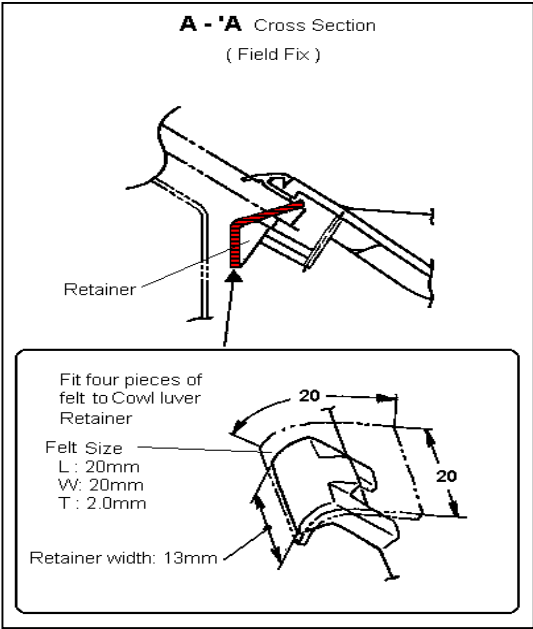

5. Cut four new pieces of felt to the dimensions shown below and apply them to the four retainers.

	Felt Size
Quantity	4
Length	20mm
Width	20mm
Thickness	2mm

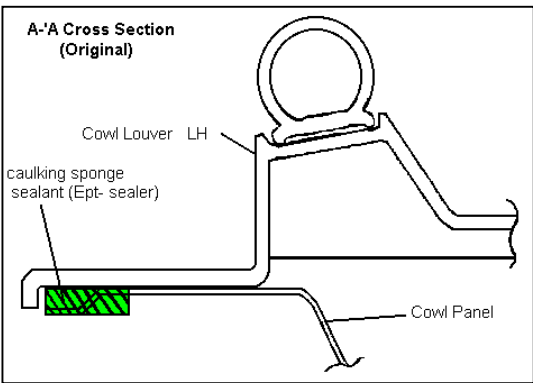

6. Add to the caulking sponge sealant (EPT-sealer) applied originally to the center cowl top ventilator louver.

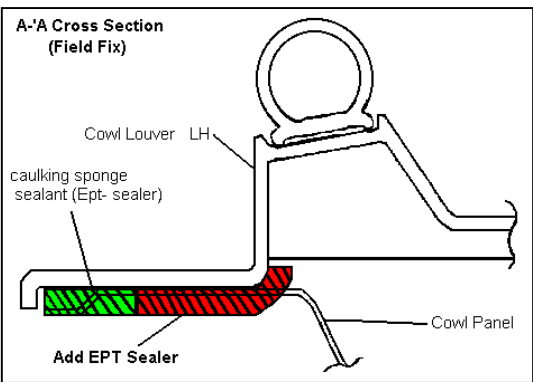

Service Bulletin

Ref. No. : WS-3001
Page : 5 of 13

7. Prepare eight new pieces of EPT sealer in the sizes shown in table below.

LOCATION	A	B	C	D	E	F	G	H	I
Quantity	1	1	1	1	1	1	1	1	1
Length (mm)	30	110	145	180	50	230	15	54	140
Width (mm)	20	20	20	20	20	20	20	10	10
Thickness (mm)	3	3	3	3	3	3	3	3	5

8. Apply the new strips of EPT sealer to the front of the cowl louver as shown below.

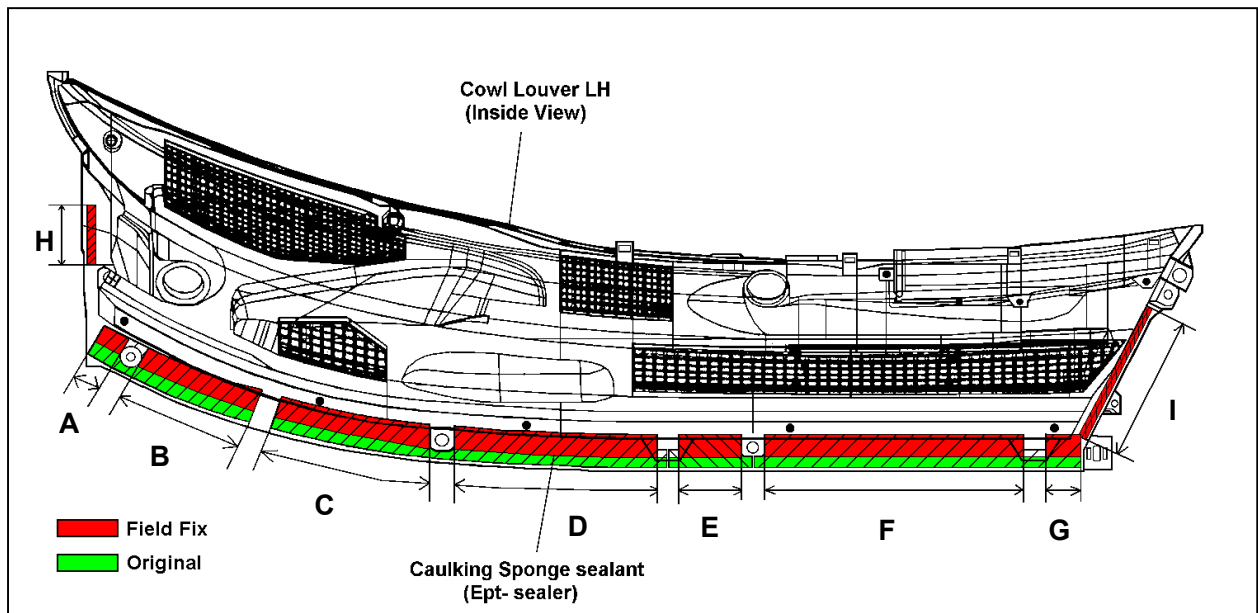

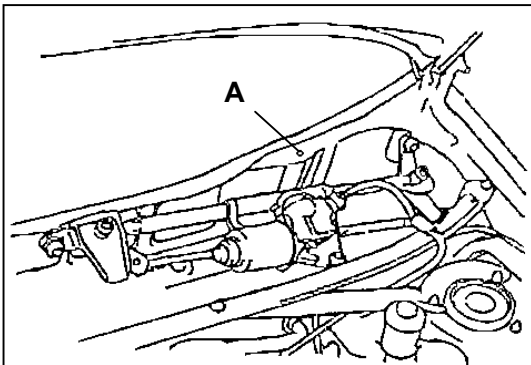

9. Prepare a new piece of felt in the dimensions shown below and apply it to a oval hole (7 × 12mm) of the dash panel. The hole can be seen behind the wiper motor assembly.

	Felt Size
Quantity	1
Length	15mm
Width	20mm
Thickness	0.5mm
Hole diameter	7×12mm

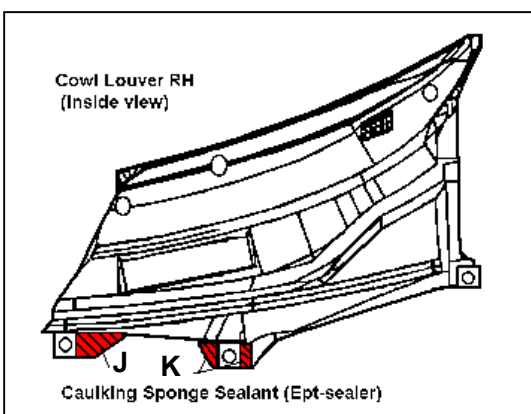
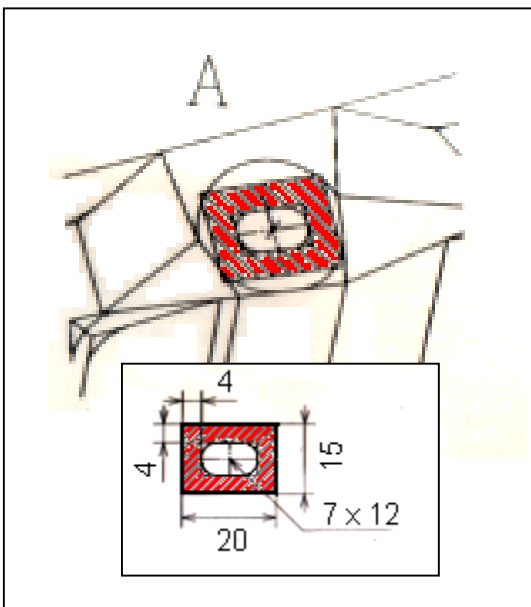

10. Prepare three more pieces of EPT sealer for the passenger's side cowl top ventilator louver/battery cover.

LOCATION	J	K
Quantity	1	2
Length	60mm	20mm
Width	30mm	10mm
Thickness	3mm	3mm

11. Trim the EPT sealer to match the shape of the cowl louver and apply it to the cowl top ventilator louver/battery cover.

Service Bulletin

Ref. No. : WS-3001

Page : 7 of 13

12. Reinstall driver's side (center) cowl top ventilator louver.
13. Reinstall passenger's side cowl top ventilator louver/battery cover.
14. Reinstall both windshield wiper arms.

Cowl Panel Field Fix Method

1. If you confirm that the tick sound continues with the cowl louver removed, proceed with the following field fix.
2. Once the cowl louver is removed, remove the wiper motor and link assembly. Unclip the wiper motor's wire harness from the cowl panel.
3. Remove the cowl panel and remove the original 2 pieces EPT sealer from the cowl panel.
4. Prepare the three new pieces of EPT sealer as listed below.

LOCATION	A	B	C
Quantity	1	1	1
Length	1190mm	230mm	30mm
Width	16mm	16mm	30mm
Thickness	10mm	10mm	5mm

Service Bulletin

- 5. Make sure that the mating surfaces are clean and apply the new EPT sealer as shown below. Make sure that the EPT sealer is extruded from the edge of the panel by 1mm while applying it to section "A".

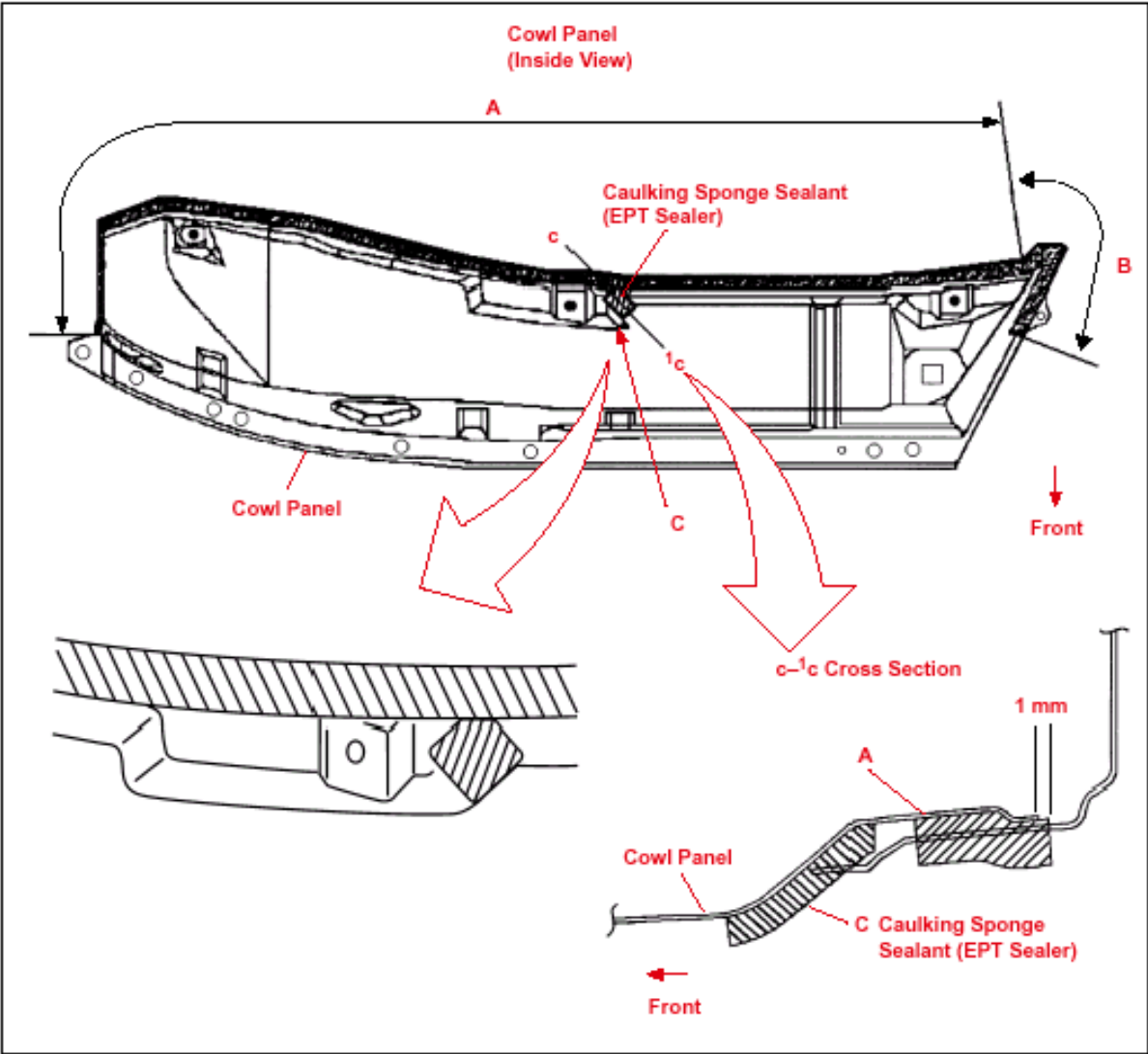

Service Bulletin

Ref. No. : WS-3001

Page : 10 of 13

6. Before reinstalling the cowl panel, add the four pieces of felt to the front suspension upper center brace as shown below.

	Felt Size
Quantity	4
Length	30mm
Width	22mm
Thickness	0.5mm

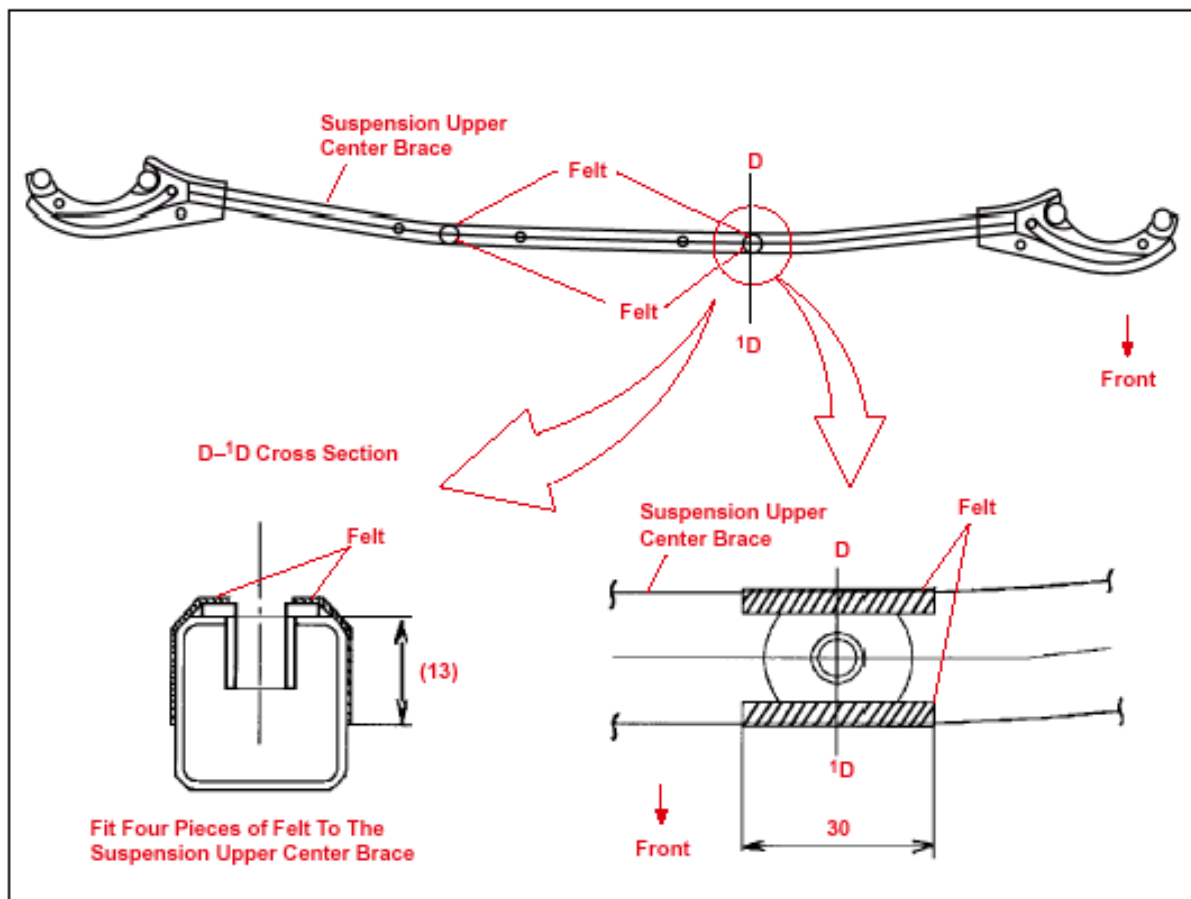

Service Bulletin

Ref. No. : WS-3001
Page : 11 of 13

7. Before reinstalling the cowl panel, apply the butyl tape or equivalent between the dash panel and the two dash panel insulator seals (yellow resin part) which are located behind the 2 center holes on the dash panel insulator outer.

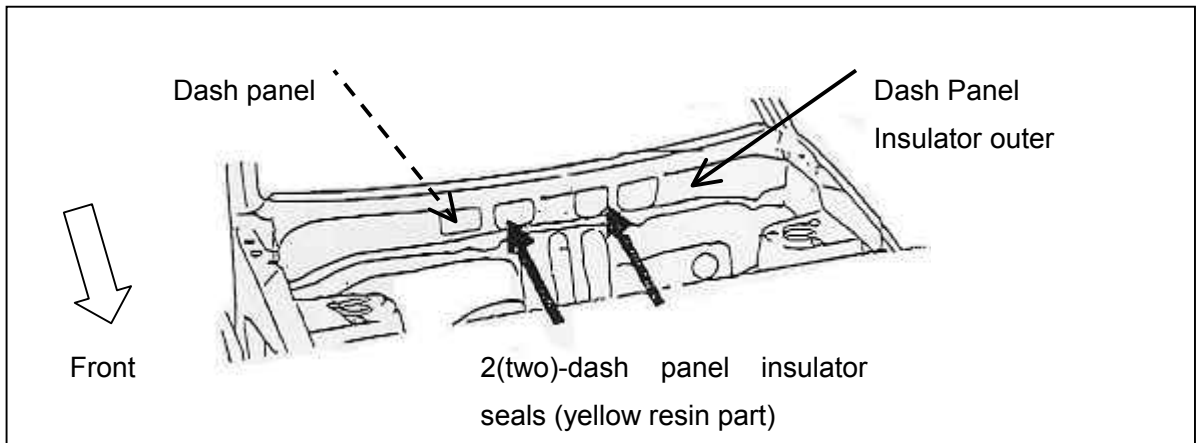

8. When applying the butyl tape, apply the tape to the both right and left sides and bottom area (shaded portions in the illustration) of the dash panel insulator seal.

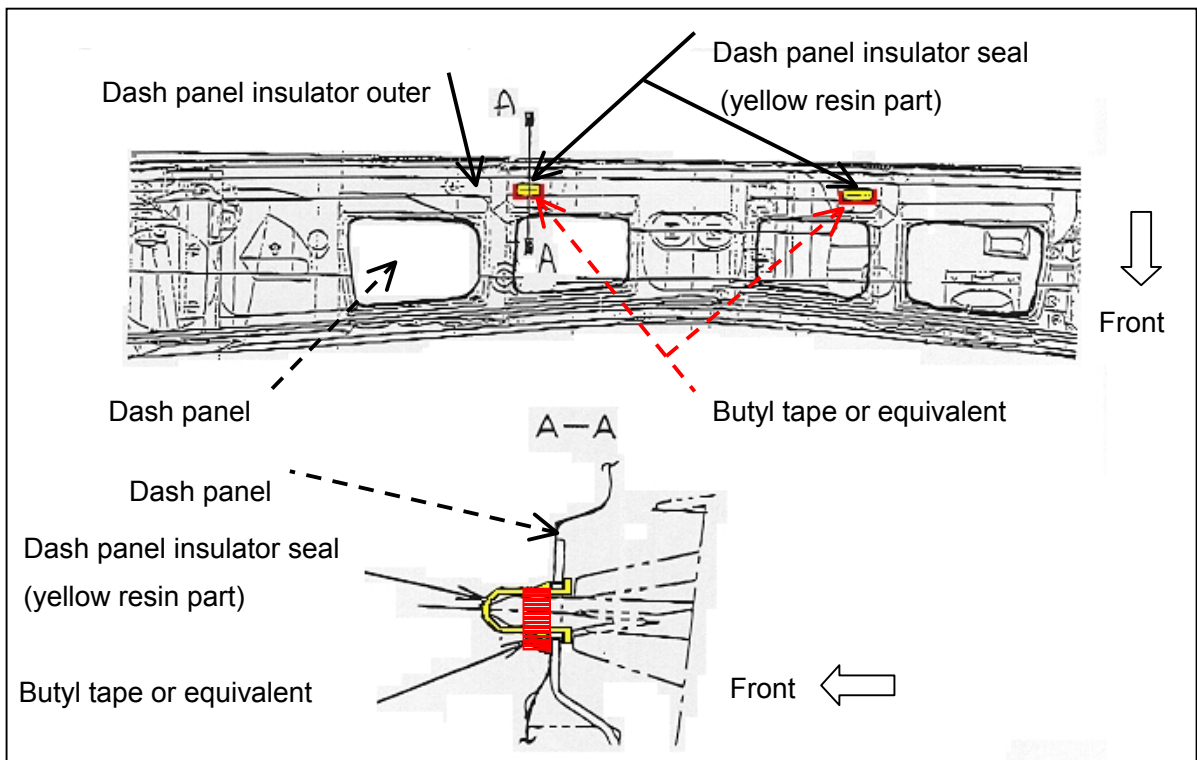

9. Reinstall the cowl panel, wiper motor and link assembly.
10. Reinstall driver's side (center) cowl top ventilator louver.
11. Reinstall passenger's side cowl top ventilator louver/battery cover.
12. Reinstall both windshield wiper arms.

Service Bulletin

Ref. No. : WS-3001

Page : 13 of 13

Latest Production Effective:

Model	VIN (Reference only)	Production Date
ACA20	JTEYH20V# #0044374~	6 th Jan. 2003
ACA21	JTEHH20V# #0221604~	6 th Jan. 2003
	JTEHH20V# #6084899~	9 th Jan. 2003
CLA20	JTEYG20V# #0013410~	6 th Jan. 2003
CLA21	JTEHG20V# #0033271~	6 th Jan. 2003
	JTEHG20V# #6026274~	9 th Jan. 2003
ZCA25	JTEGR20V# #0016776~	6 th Jan. 2003
ZCA26	JTEGR20V# #0037501~	6 th Jan. 2003
ACA26	JTEGH20V# #0099094~	6 th Jan. 2003